

Operating manual Water pump „Genova“

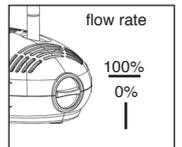

5. Assembly and Start-up

1. Completely unroll the connecting cable on the pump.
2. Measure the depth of water of your garden pond.
3. Firmly connect the individual ascending pipes until the pipe protrudes from the water surface. In case the enclosed ascending pipes should not be sufficient, you may also order those pipes as spare parts from the manufacturer. Now attach the sprinkler you want to use.
 - **Note:** When using the water bell it is possible to adjust the diameter of the bell by screwing in or out of the upper part.
 - **Note:** Please make sure that the pump is not directly placed on the pond bottom. A particularly high amount of dirt is sucked in here which would lead to a fast clogging of the nozzles. Therefore, please place the pump approximately 20 cm above the pond bottom onto stones.
4. Depending on the use, the pump may be operated directly via a solar module, a battery box or a DC power supply unit (12 to 24 VDC) and or a solar battery. Now connect the plug with the socket on the solar module or the battery box. A cable piece with open ends is included in the scope of delivery for the connection to a power supply unit or battery. Please note that, in this case, the **brown cable** is the **positive pole** and the **blue cable** is the **negative pole**.
 - **Note:** The plug is protected against reverse polarity; please do not apply force when plugging it in.
5. If the delivery rate of the pump should be too high, you may reduce the amount of water. For this purpose, simply rotate the controller at the front side of the pump clockwise. Do not apply force when adjusting. The adjustment range amounts to 45°.



Customer support:

If you have problems or questions regarding this product, simply contact us!
Monday to Friday 9 am to 12 noon and 1 pm to 4 pm.
 By phone: 09605-92206-0
 By e-mail for ordering spare parts: ersatzteil@esotec.de
 By e-mail for questions about the product: technik@esotec.de
Product: Manufacturer Item No.: 101735

These instructions relate **ONLY** to this product and contain important information for using the product for the first time. Please keep these instructions for later reference and should always accompany the product in the event of transference to a new user.

1. Introduction

Dear Customer,

Thank you for purchasing the water pump. With this water pump you purchased a product manufactured according to the current state of technology.

CE This product fulfils all requirements of the valid European and national regulations. The conformity was proved. The relevant declarations and documentation are deposited with the manufacturer.

To maintain this state and guarantee a safe operation, you as the user will have to follow this operating manual!

2. Safety Instructions



- In case of damages caused by not following this operating manual, the warranty rights will expire! We exclude liability for any consequential damages!
- We exclude liability for property or personal damages caused by inappropriate handling or not following the safety instructions.

- In these cases any guarantee rights will expire.

Due to safety and admission reasons (CE) it is not allowed to arbitrarily reconstruct and/or change the water pump.

Therefore, please keep to the operating manual.

The accident prevention rules of the association of the industrial trade cooperative association for electric plants and working material are to be considered in industrial environments.

3. Intended Use

This submersible pump is designed for the pumping of water in the garden pond, fountain, water trays or similar. It can pump water via a gland or it may be operated via enclosed ascending pipes with water sprinklers.

A solar module or a power supply unit with a voltage of 12 - 24 Volts can be used as energy source. If used in combination with a solar module the pump will only work if the solar module is exposed to sufficient solar radiation.

The delivery rate of the pump can be adjusted via the controller on the front side of the pump. The water pump does not have any ON/OFF-switch. The pump starts pumping water as soon as it is connected to the power supply.

4. Overview

1. Ascending pipes
2. Water nozzle with a 3-stage sprinkler
3. Water nozzle for the water bell
4. Water-Air nozzle
5. Controller for the delivery rate
6. 5 m Connecting cable including plug
7. Locking for the pump case
8. Connecting cable with open ends (only included in single pumps and not in sets)



6. Protection against dry Running

The pump is standard-equipped with a protection against dry running. 2 sensor points at the side of the case are installed for this purpose. The pump will work if those points are under water. **The pump won't work if one point should protrude from the water!**

Those points have to be cleaned with a sponge and water when servicing or cleaning the pump.



7. Service and Maintenance

In order to maintain the performance of the pump it is required to occasionally, depending on the water contamination, rinse the pump with warm water. For this purpose, open the case as follows:

Note: Please do not apply force when assembling and disassembling the pump. The parts are very delicate and may break easily.

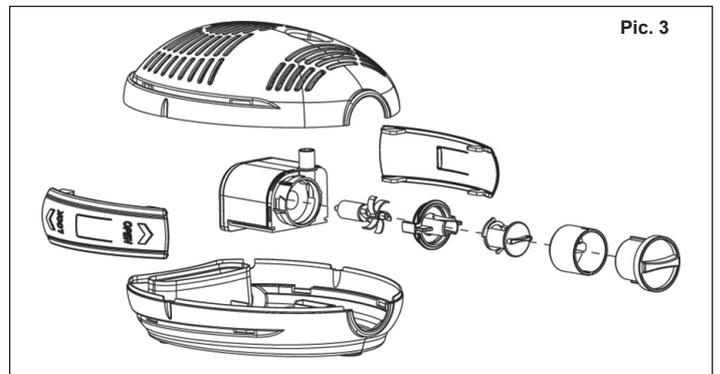
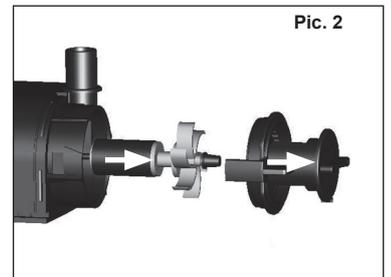
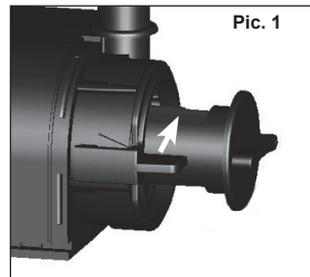

1. Disconnect the power supply of the pump
2. Remove the ascending pipe from the pump.
3. Push the two lateral locks into the position „OPEN“ and take it off to the side.
4. Carefully open the pump case.
5. Take the pump out of the case.
6. Rotate the front cover of the pump by approx. 45° clockwise (illustration 1) and carefully pull the cover to the front (illustration 2). In doing so, please pay attention to the ceramic shaft and the seal.

7. Carefully pull the impeller wheel out of the pump (possibly use small tongs as an aid). (illustration 3).
8. Now carefully clean all parts with warm water.
9. Now carefully insert the shaft with the impeller wheel into the hole of the pump. In doing so, pay attention to the tight fit of the shaft and brackets on both sides of the shaft.
10. Now carefully attach the cover onto the pump. In doing so, pay attention to the tight fit of the seal.
11. Now rotate the front cover by 45° anticlockwise into its initial position.
12. Now reassemble the pump in reverse order.
13. Pay attention to the correct fit of the connecting cable through the case.

The pump is now again ready for operation.

8. Malfunctions

The pump does not pump any water

- Is the pump completely immersed in the water? Protection against dry running (item 5)
- Is the supply voltage connected with reverse polarity? Cable color brown = positive pole, blue = negative pole.
- Pump contaminated? Cleaning of the pump, see item 6.
- Sensor points of the protection against dry running dirty? Clean the points!
- When the pump is freshly immersed in the water, there may still be air in the area of the pump wheel. This is why no water can be pumped. Remedial action: fill water into the ascending pipe with a watering can when the pump is applied.

9. Technical Data

- | | |
|---|-------------------------------------|
| • Operating voltage: | 12 - 24 V DC |
| • degree of protection: | IP 68 |
| • Protection class: | III |
| • Max. water depth: | 2 m |
| • Discharge head/flow rate 12V/17V/24V: | max. 1 m / 2,4 m / 3,5 m |
| • Discharge 12V/17V/24V: | max. 1200 l/h / 1700 l/h / 2000 l/h |
| • Power consumption 12V/17V/24V: | approx. 8 W / 20 W / 35 W |
| • Operating temperature range: | +4 to +40°C |
| • 5 m extension cable: | 101736 |

Note: The pump is only suitable for the delivery of water.

Note: Protect the pump against frost!

During cold winter months, it is required to take the pump out of the water and store it at a frost-free place. The solar module may be left outside during the winter.

10. Safety Information:

DANGER for children! Keep children away from the swallowable small parts (ascending pipe and sprinkler) and the packaging material. Danger of suffocation!

WARNING tripping hazard! Lay the connecting cable so that it won't become a tripping hazard!

CAUTION Material damage! If you set up the solar module without the module retainer, please pay attention to an adequate stability. The solar module may be damaged if the module should tilt or in case of an impact by a foreign body.

11. Spare Parts

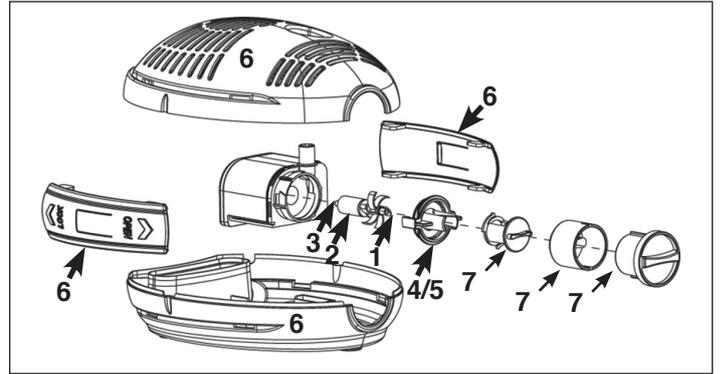

Type

1. Ceramic shaft white:
2. Pump wheel:
3. Rubber socket inside:
4. Cover front:
5. Seal for cover:
6. Pump trays complete:
7. Flow controller:
8. Nozzle set complete:

Milano

- Art.-No.: 911060
 Art.-No.: 911061
 Art.-No.: 911062
 Art.-No.: 911063
 Art.-No.: 911064
 Art.-No.: 911075
 Art.-No.: 911076
 Art.-No.: 911067

Manufacturer/Importer

esotec GmbH - Gewerbegebiet Weberschlag 9 - D-92729 Weiherhammer
 Tel.-Nr: 09605-92206-0 - Fax.-Nr: 09605-92206-10 - Internet: www.esotec.de

Disposal:

Dear customer,
 please cooperate in avoiding waste. When you intend to dispose of the product in future, please consider that it contains valuable raw materials suited for recycling.
 Therefore, do not dispose it of with domestic waste but bring it to a collection point for the recycling of waste electrical and electronic equipment.

Thank you very much for your cooperation!



Copyright, esotec GmbH